

Front View

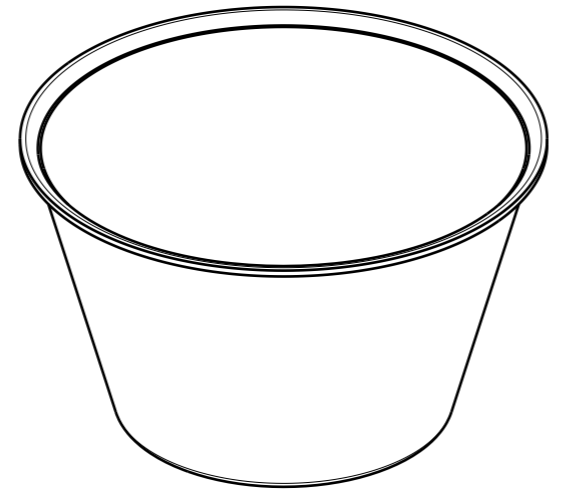

Isometric View

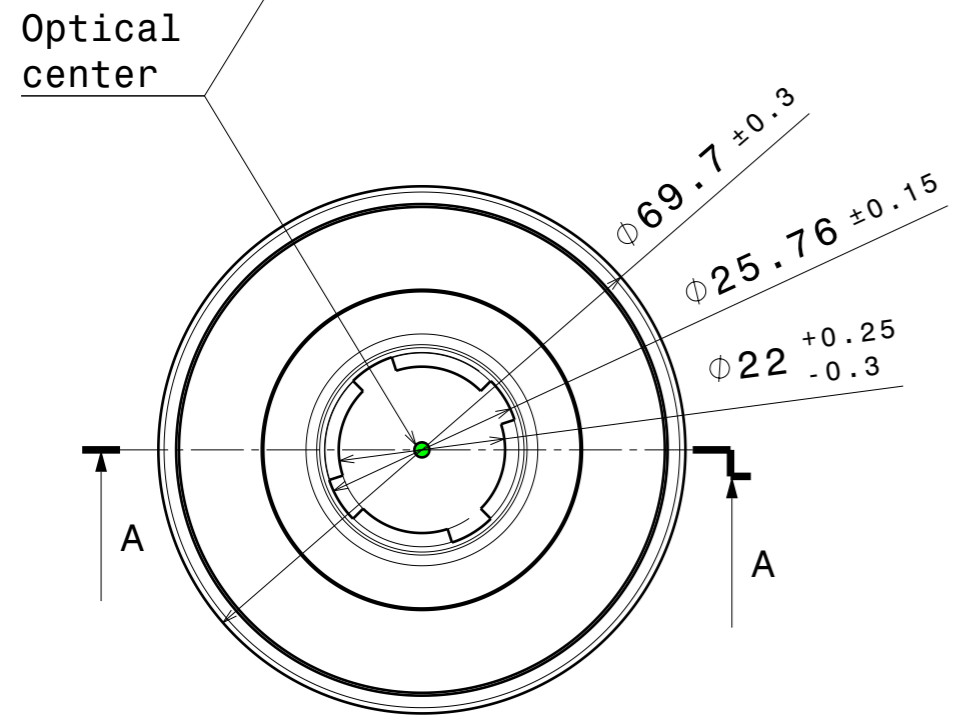

Top View

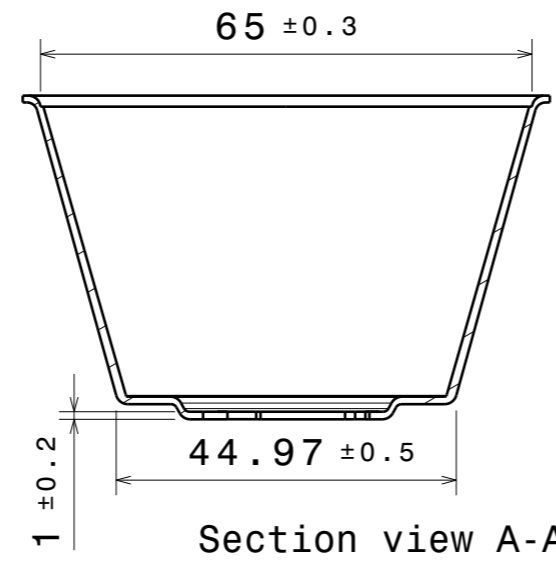

Section view A-A

Example assembly with Hekla socket:

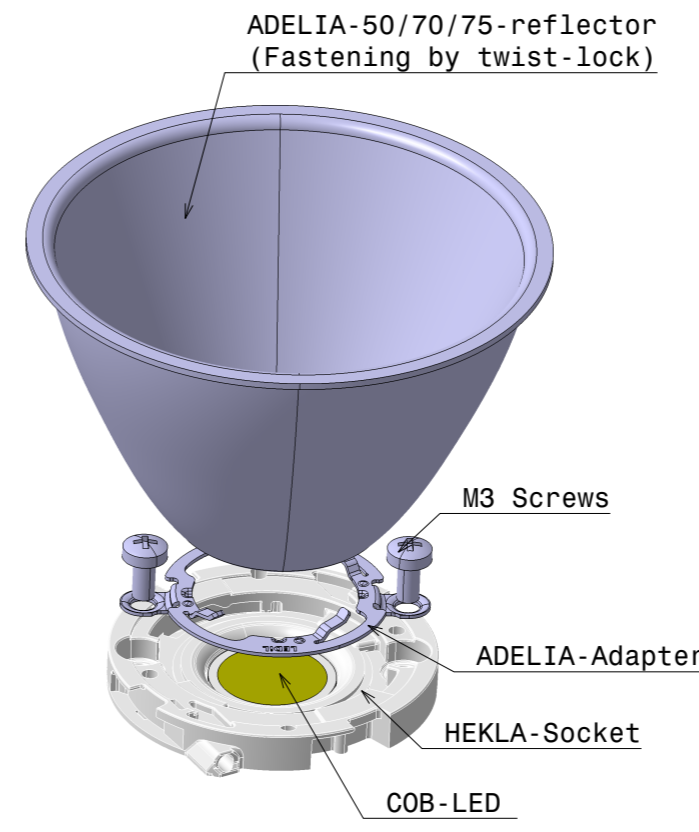

Example assembly with slim Ø 35mm BJB socket:

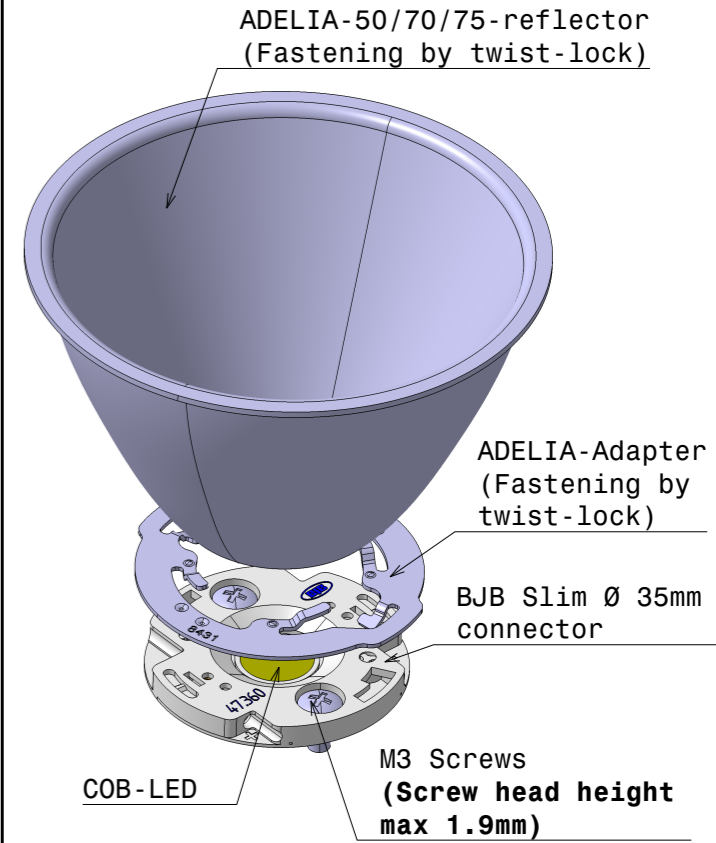

PART	TYPE	MATERIAL	COLOR / COATING
C18986_ADELIA-70-WW2	Reflector	Aluminium	Polished

MECHANICAL DRAWING	
PRODUCT	ADELIA
Plastic moulding general tolerances according to DIN 16901-130 and applies if not otherwise shown in the drawing. Silicone moulding general tolerances according to ISO 3302-1 Class M3 and applies if not otherwise shown in the drawing.	FIRST ANGLE PROJECTION:
SCALE 1:1	WEIGHT -

LEDiL

This drawing is the property of LEDiL Oy. It may not be copied or otherwise distributed without prior written permission from LEDiL Oy.

A3 SHEET 1/1

Notes

- PCB or heatsink level.
- LED location
- Ensure LED fitting from a product specific 3D model available from www.ledil.com
- For more details about installation please see LEDiL Installation Guide on www.ledil.com